

Indian Institute of Technology, Kharagpur
Mid-Autumn Semester Examination, 2016
 Mechanical Engineering Department
Subject: Mechanics of Solids Subject No. : ME 31013

Time : 2 Hrs

Full Marks : 30

Adopt appropriate assumption if it is necessary and the stresses mentioned here refer to the Cauchy stresses. Unless otherwise mentioned, all dimensions in Figs. 2 and 3 are in mm.

1. (a) When and why principal stresses are real? Prove that the principal planes for the distinct principal stresses are orthogonal to each other. (1+2)

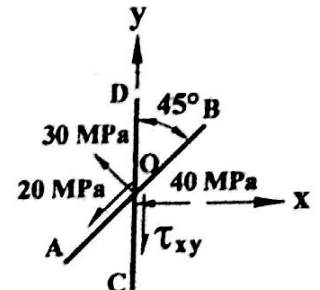

Fig. 1

- (b) Figure 1 shows the normal and shear stresses at a point (O) of a deformed solid body based on the two planes AB and CD. The solid does not have body couples and is in equilibrium. Assuming the state of stress at the point as the state of plane stress problem, compute the shear stress τ_{xy} at the point as shown in the figure. (3)

2. The displacement field in a deformed solid is given by

$$u = (3x^2y + 6) \times 10^{-2}, \quad v = (6xz + y^2) \times 10^{-2} \quad \text{and} \quad w = (6z^2 + 2yz + 10) \times 10^{-2}$$

- (a) Calculate the state of strain at a point (1, 0, 2) and the longitudinal strain at the same point along the line $2x + \sqrt{3}y - 3z + 4 = 0$. (3+2)

- (b) If the solid is homogeneous and isotropic and its Young's modulus and Poisson's ratio are 200GPa and 0.3, respectively, determine the octahedral stresses at the same point. (3)

3. A straight prismatic beam made of homogeneous isotropic solid is loaded as shown in Fig. 2. The line of action of the load passes through the centroid of the cross-section at the mid-span of the beam and is tangential to this cross-section. Find the neutral axis in the cross-section and compute the normal stress at point A. Assume that the beam is simply supported. (6)

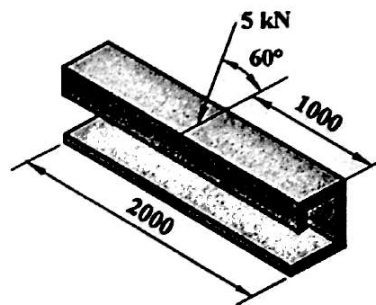
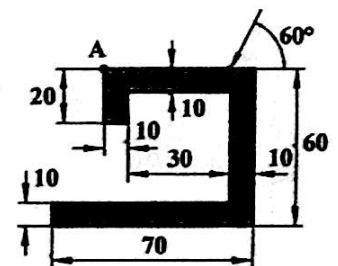

Fig. 2



Enlarged Section at Mid-Span

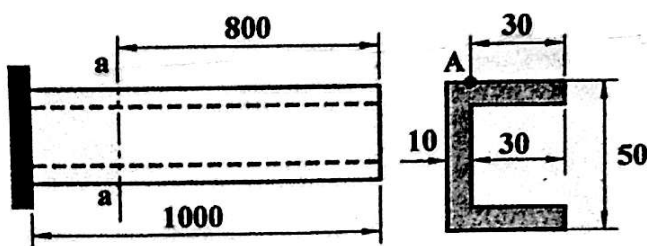

Fig. 3

Enlarged Section a-a

4. (a) Why the formula $\tau = VQ/(I_y t)$ is used for computing the transverse shear stresses in a beam instead of using the stress-strain relation? (2)

- (b) A cantilevered homogeneous isotropic prismatic beam is shown in Fig. 3. The beam is subjected to an upward transverse load of 10 kN at the free end of the beam.

Find the line of action of the load such that the bending-twisting coupling does not occur in the beam. Also, determine the principal stresses at a point A. The point A is located at section a-a as shown in Fig. 3. Wall thickness of the beam is uniform. (5+3)